

# Rotary Distributors

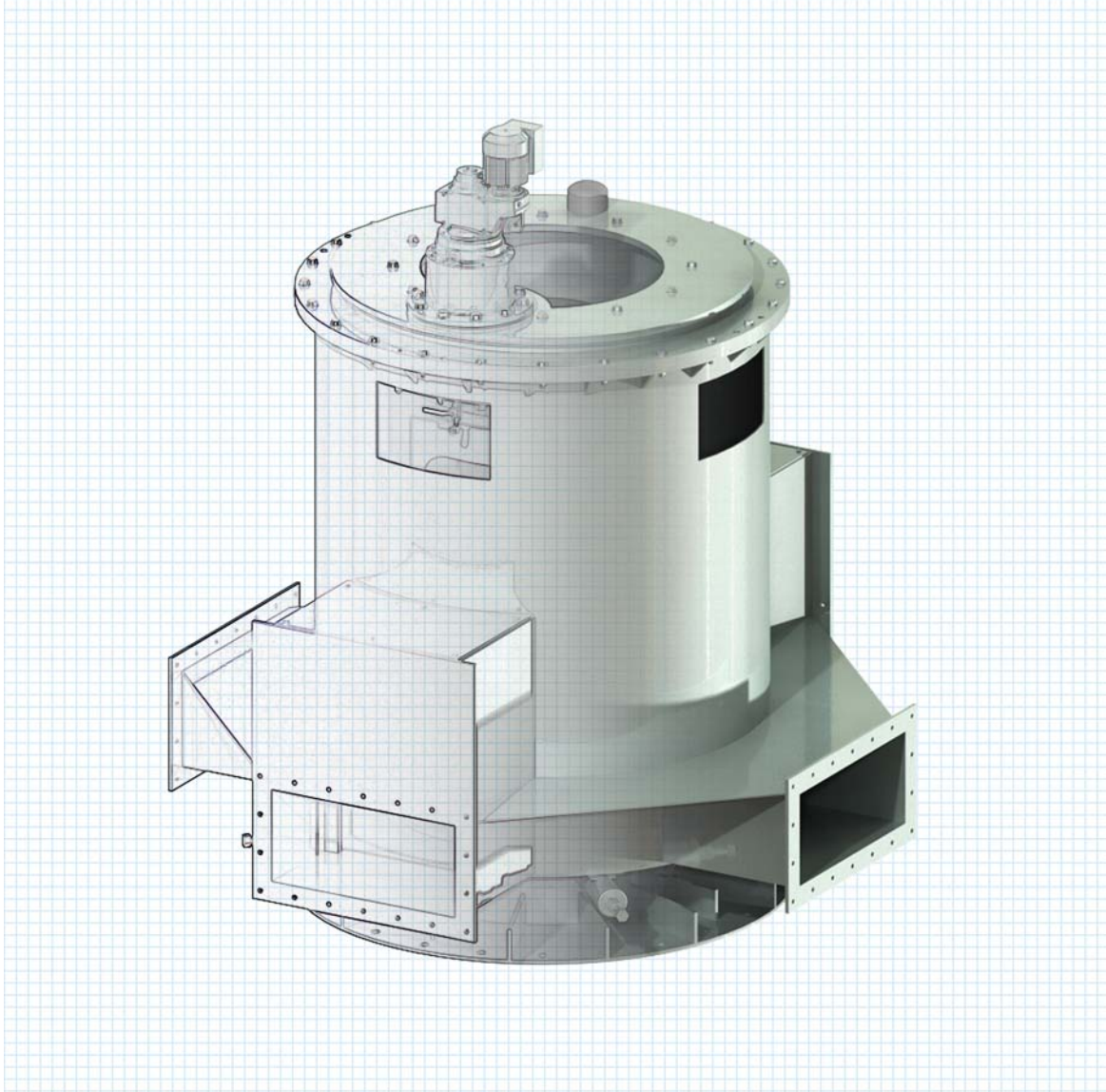

**DBS MANUFACTURING®**

## Rotary Distributor Center Mechanisms for Trickling Filters



DBS rotary distributor center mechanisms are available in 2, 3, 4, or 6 arm configurations as a rotary reaction type (hydraulically driven) or motorized type (motor driven).

The motorized rotary distributor turns at a controlled speed regardless of flow. This allows the operator to control the dousing rate.

DBS rotary distributors are designed for all standard influent pipe sizes from 8 inches to 48 inches (200 mm to 1200 mm). Standard models are made from steel pipe and plate and are hot dip galvanized. DBS rotary distributors are also available in aluminum and stainless steel construction.

The DBS rotary distributor center mechanism represents state of the art in reliability and simplicity. One specially designed precision bearing supports the entire rotating mechanism. The bearing is top running and is safely away from damaging water and moisture.

MODEL	MAX. FLOW RATE <sup>1</sup>		CENTER INFLUENT COLUMN DIAMETER	
	GPM	LPS	inches	mm
RD-8	625	39	8	203
RD-10	979	62	10	254
RD-12	1,410	89	12	305
RD-14	1,719	108	14	356
RD-16	2,428	153	16	406
RD-18	2,914	184	18	457
RD-20	3,818	241	20	508
RD-24	5,522	348	24	610
RD-28	7,270	459	28	711
RD-30	8,376	528	30	762
RD-36	12,185	769	36	914
RD-42	16,460	1,038	42	1,067
RD-48	21,630	1,364	48	1,219

<sup>1</sup>Maximum flow rates are based on a velocity of four feet per second.

# Rotary Distributors

## Features

### Sealless Design

The DBS sealless rotary distributor center mechanism reduces maintenance and breakdowns. If the arms clog and flow backs up into the rotary distributor, the overflow simply discharges between the distribution manifold and influent column. Access ports are provided for easy maintenance and cleaning.

### Warranty

A 5-year bearing warranty.

### Options

A shear pin mechanism or a slip clutch device protects the entire motorized rotary distributor in the event binding occurs.

### Reversibility—Motorized Models

Motorized rotary distributors can be reversed and back-driven. This feature is particularly useful during start-up and installation.

### Torque Overload Protection

Stainless steel or aluminum construction. High-Low flow splitter baffles.

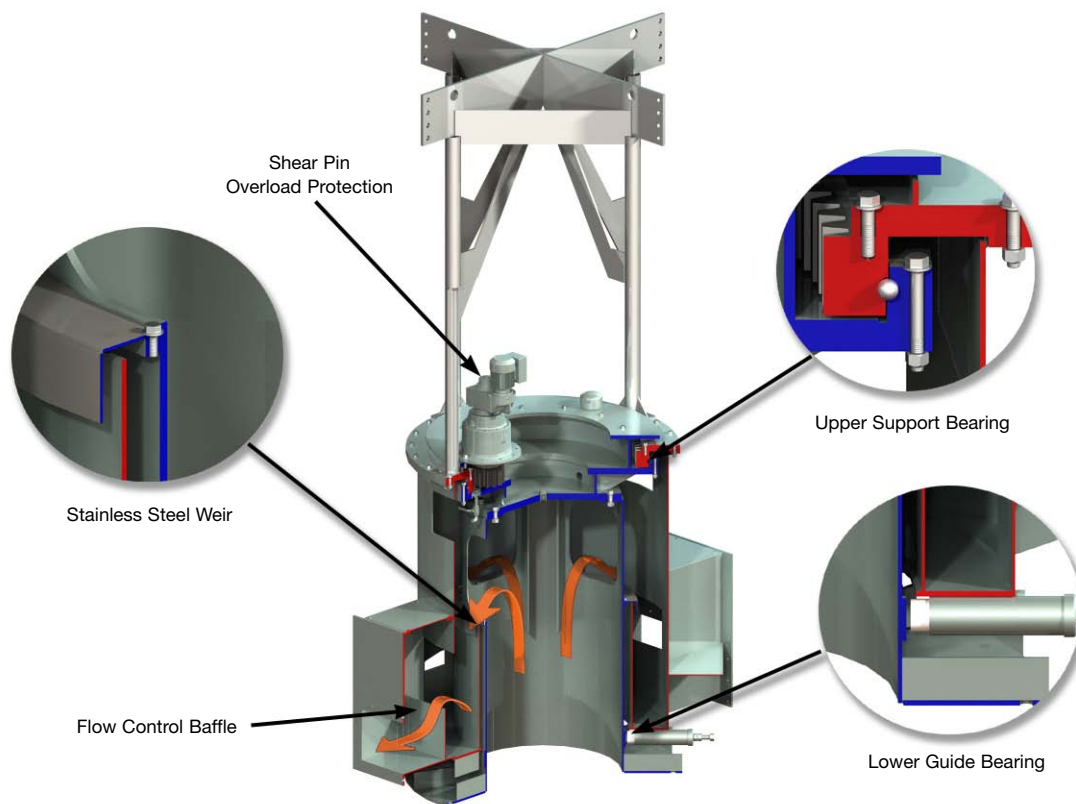

### UPPER SUPPORT BEARING

Heavy duty precision bearing for combined thrust, moment, and radial loading. Bearing can be replaced without removing the distribution manifold, arms or influent column.

### WEIR

Flow cascades over the stainless steel weir and enters the distribution manifold.

### LOWER GUIDE BEARING

A supplemental bearing is provided to prevent the rotary distributor from tipping in the event of extremely unbalanced loads. The bearing is made of high strength, corrosion resistant, maintenance-free, ultra-high molecular weight (UHMW) material.

# Rotary Distributors

## Dimensions

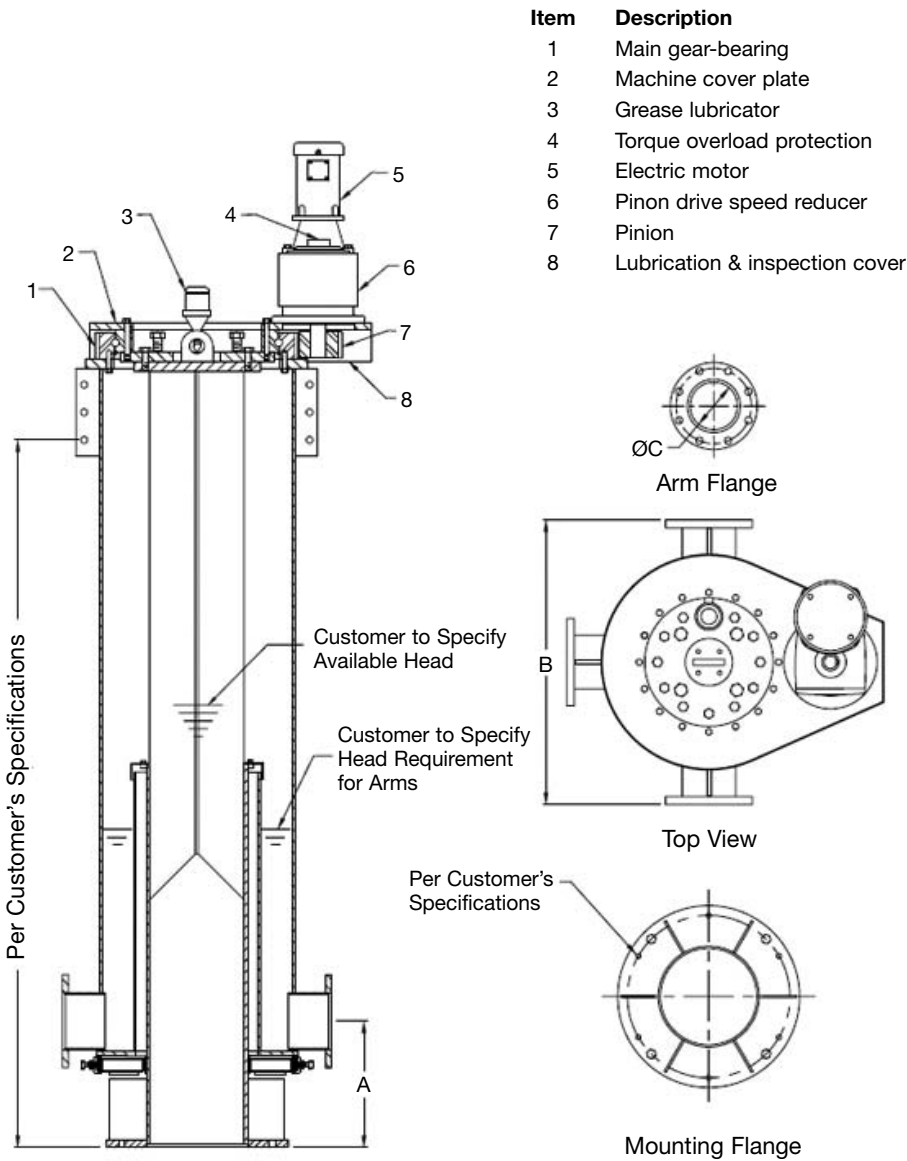

Model	A		B		C		Weight	
	in	mm	in	mm	in	mm	lb	kg
RD-8	15	381	24	610	4.026	102	1,600	726
RD-10	15	381	28	711	5.047	128	2,000	907
RD-12	16	406	34	864	6.065	154	2,700	1,225
RD-14	16	406	6	914	7.981	203	3,200	1,452
RD-16	16	406	38	965	7.981	203	3,600	1,633
RD-18	18	457	42	1,067	10.02	255	4,200	1,905
RD-20	18	457	46	1,168	10.02	255	4,800	2,177

Metric flanges are available.

# Rotary Distributors

## Dimensions

- | Item | Description                 |
|------|-----------------------------|
| 1    | Oil drain valve             |
| 2    | Intermediate speed reducer  |
| 3    | Torque overload protection  |
| 4    | Electric motor              |
| 5    | Primary drive speed reducer |
| 6    | Pinion                      |
| 7    | Oil fill & inspection       |
| 8    | Machine cover plate         |
| 9    | Output drive plate          |
| 10   | Main gear-bearing           |

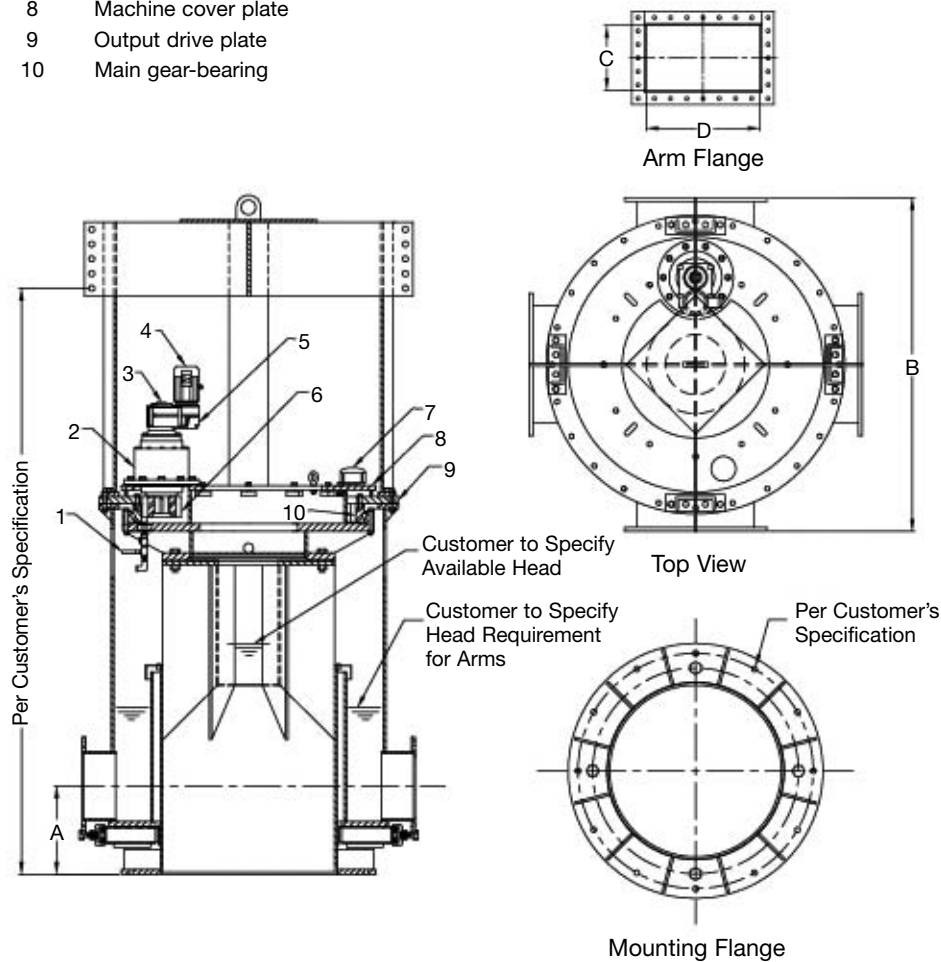

Model	A		B		C		D		Weight	
	in	mm	in	mm	in	mm	in	mm	lb	kg
RD-24	16	406	52	1,321	5	127	21	533	5,500	2,495
RD-28	16	406	56	1,422	7	178	23	584	6,000	2,722
RD-30	18	457	64	1,626	9	229	25	635	8,000	3,629
RD-36	18	457	68	1,727	11	279	27	686	9,000	4,082
RD-42	20	508	84	2,134	13	330	29	737	11,000	4,990
RD-48	20	508	86	2,184	15	381	31	787	12,000	5,443

Metric flanges are available.

## General Engineering Specification for Rotary Distributors

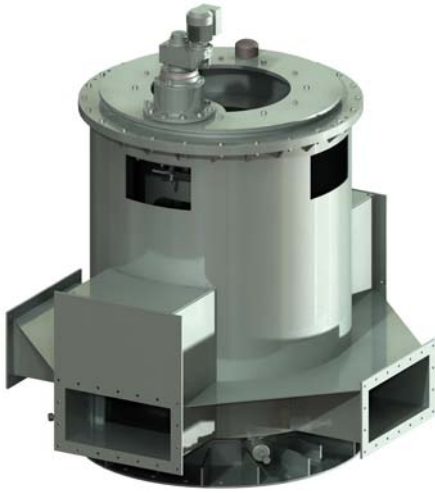

The Rotary distributor center mechanism shall be of the top running bearing type and shall consist of a stationary influent column, precision bearing, and a rotating distribution manifold. The influent column shall be attached to the support base of the trickling filter. The influent column base plate shall include four leveling bolts for assisting in leveling the rotary distributor during installation. The precision bearing supports the entire rotating mechanism. The distribution manifold shall be bolted to the rotating raceway of the bearing assembly.

The precision bearing shall be a four-point-contact design. The bearing balls shall be separated by Nylon spacers to prevent ball-to-ball sliding friction. The bearing shall be oil bath or grease lubricated and have seals to prevent dirt and water from entering bearing raceway. The bearing shall be safely located away from damaging water. The bearing shall be replaceable without removing the distribution manifold, arms, and influent column. The bearing shall have an L10 Life in excess of 100,000 hours.

The influent column assembly and the rotating distribution manifold shall be constructed of steel pipe and flanges. All pipe shall be of standard schedule (0.375" wall thickness) on 12 inch pipe and larger, and schedule 40 on 10 inch pipe and smaller. Bearing mounting flanges shall have a minimum thickness of 1 inch. All welds shall conform to AWS specifications. All exposed steel components shall be near white blast cleaned (SSPC-SP10) and shall be hot dip galvanized, excluding machined surfaces and power train components. If required, an annular baffle for restricting low flow to a portion of the distributor arms and for splitting high flow to all arms shall be provided.

Rotary distributors that are motor driven shall have a power train consisting of an electric motor, intermediate gear reduction unit, and a final reduction pinion and gear. The final reduction gear shall be integral with the top running bearing. Gear teeth shall have a core hardness of 250-300 Brinell. Gear teeth shall be made to AGMA grade 6 or higher. The main gear and pinion shall be rated per AGMA standard 2001-C95 for a life in excess of 200,000 hours. The gear reduction units shall be of the spur gear or helical type to allow the trickling filter to coast after the power is cut off. A torque overload protection device such as a shear pin or slip clutch shall be provided in case binding of the trickling filter were to occur. Power train components shall be protected with a heavy duty paint system.

# Rotary Distributors

## Ordering Information

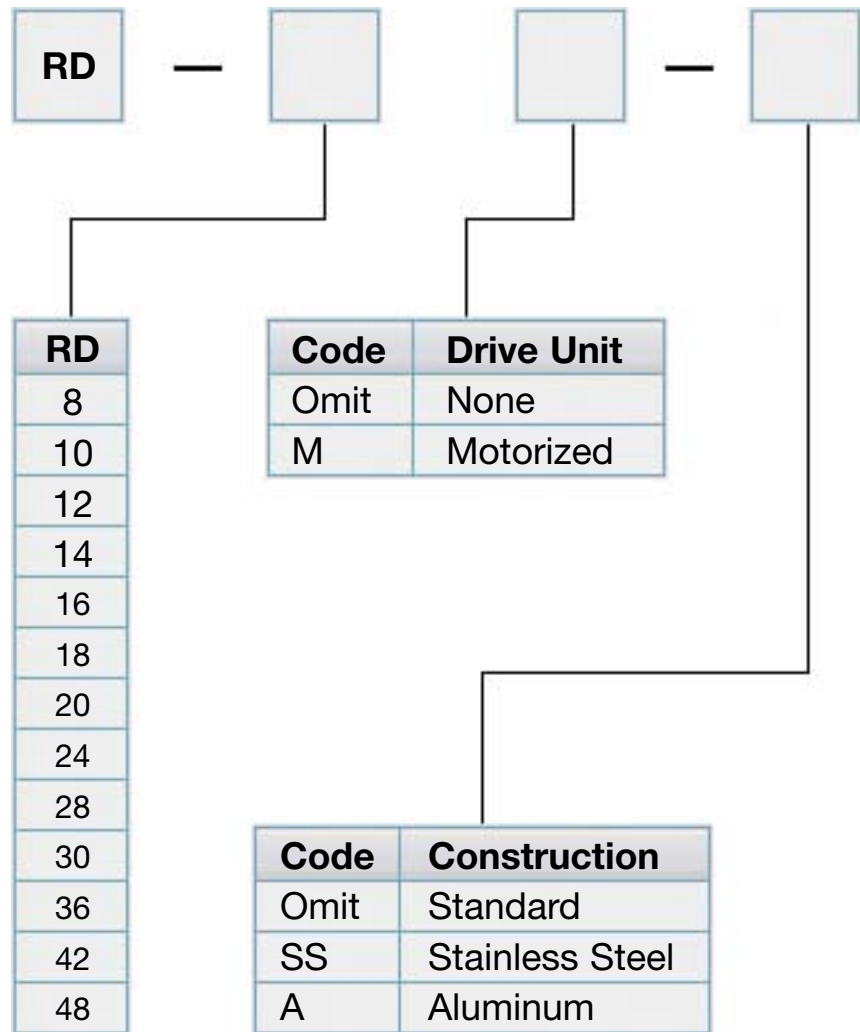

## Options

- Stainless steel or aluminum construction
- High-Low flow splitter. Internal annular baffles for flow restriction to the arms
- High-Low flow splitter. External flow splitter boxes for flow restriction to the arms
- 2, 3, or 6 arm design (4 is standard)

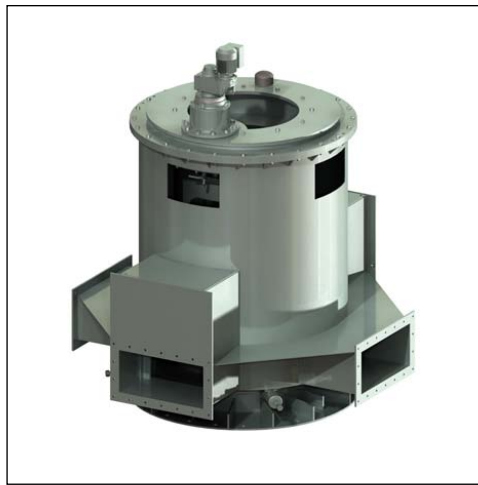

**Rotary Distributors  
Center Mechanisms for Trickling Filters**

**Clarifier & Thickener Drives**

**Retrofits**

**Low-Speed Surface Aerators**

**Rotary Distributor Center Mechanisms**

## **DBS Manufacturing, Incorporated**

45 SouthWoods Parkway, Atlanta, Georgia 30354 USA

404.768.2131 phone 404.761.6360 fax

www.dbsmfg.com email: [engineering@dbsmfg.com](mailto:engineering@dbsmfg.com)