

Low Speed Aerators

NSA Series Aerators

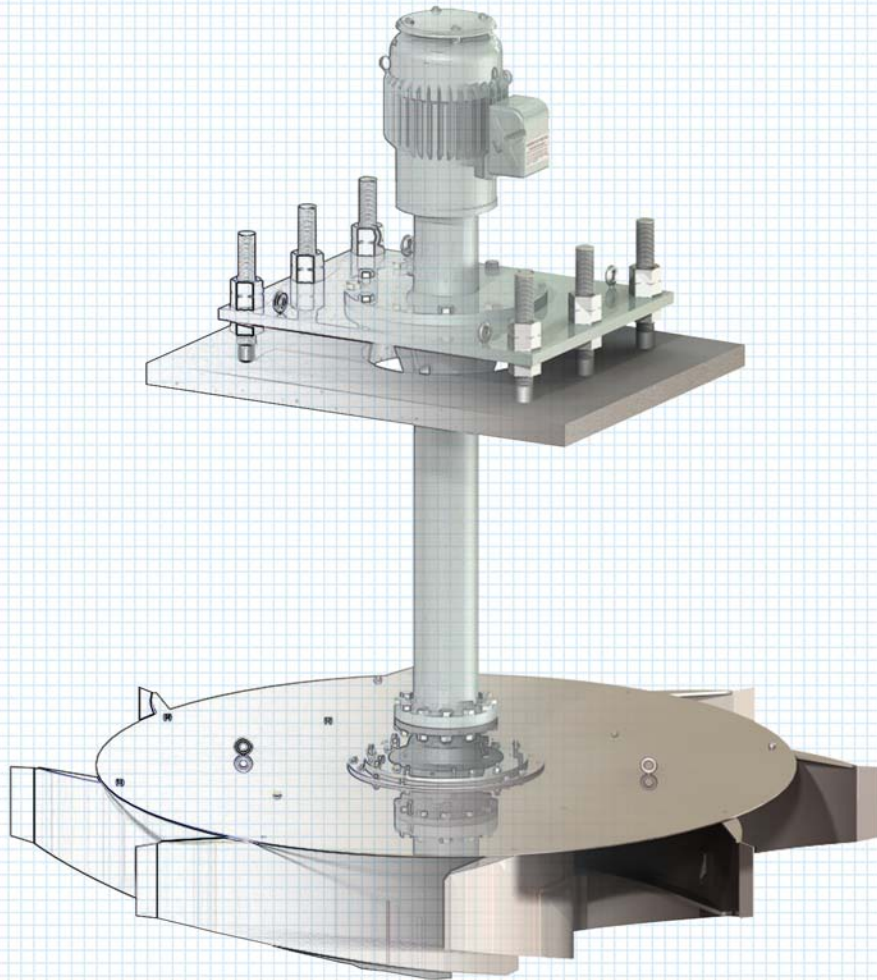

DBS MANUFACTURING®

Low Speed Aerators

NSA Series Aerators

Surface mechanical aerators fall into two categories: high-speed aerators and low-speed aerators.

- High-speed aerators use an electric motor to directly drive a pump impeller which pumps water up and sprays it out horizontally. While this design is inexpensive, it has low oxygen transfer efficiency because the pump impeller turns at higher-than-optimum aeration speed and wastes significant amounts of energy in moving water faster than needed.
- Low-speed aerators are higher in efficiency than high-speed aerators because the aeration rotor operates near the optimum aeration speed. However, low-speed aerators are more expensive because they must use a gearbox to reduce motor speed to turn a large diameter aeration rotor. In addition, the gearbox is typically mounted a few feet above the rotor and requires a long and large shaft with substantial supporting bearings.



Before the DBS NSA was introduced to the market, a user had to weigh the benefits of long-term power savings of the low-speed, high-efficiency aerator against the initial capital savings of the high-speed, low-efficiency aerator.

Now the DBS NSA low-speed aerator provides the best features of low-speed and high-speed aerators: HIGH-EFFICIENCY AT A LOW COST. The DBS NSA low-speed aerator is cost competitive with high-speed aerators and offers the efficiency and power savings of the low-speed aerator. The power savings can be significant, in the range of 20% or more.

Patent Drawing

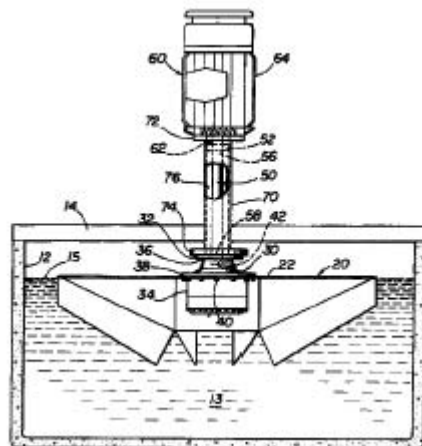

Low Speed Aerators

NSA Technical Features

GEARBOX

The NSA aerator uses a planetary gearbox to drive the aerator rotor. This type gearbox is mass-produced and offers an excellent power/cost ratio. The gearbox is mounted directly in the aerator rotor. This unique arrangement provides a number of benefits:

1. The gearbox operates partially submerged. Water flowing through the impeller cools the gearbox to near ambient temperature. The low operating temperature allows long oil life.
2. The gearbox directly drives the rotor so there are no driveshaft or inherent driveshaft vibration problems common in traditional low-speed aerators.
3. The gearbox and rotor assembly is attached to the electric motor by a “torque tube.” This tube can flex laterally to dampen shocks caused by wave impact on the rotor.

ROTOR

A traditional high-efficiency back-curved radial blade rotor or a DBS advanced flexible radial blade rotor is available on the NSA. See details on the rotor page.

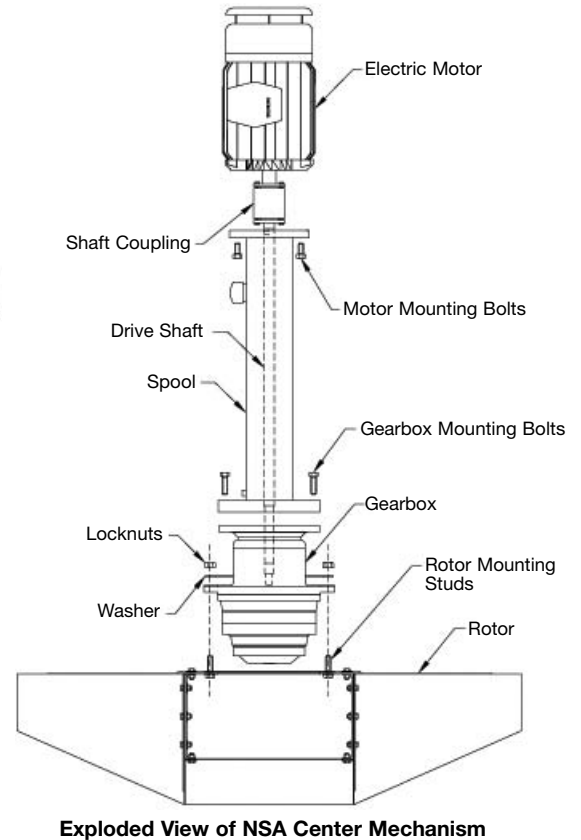
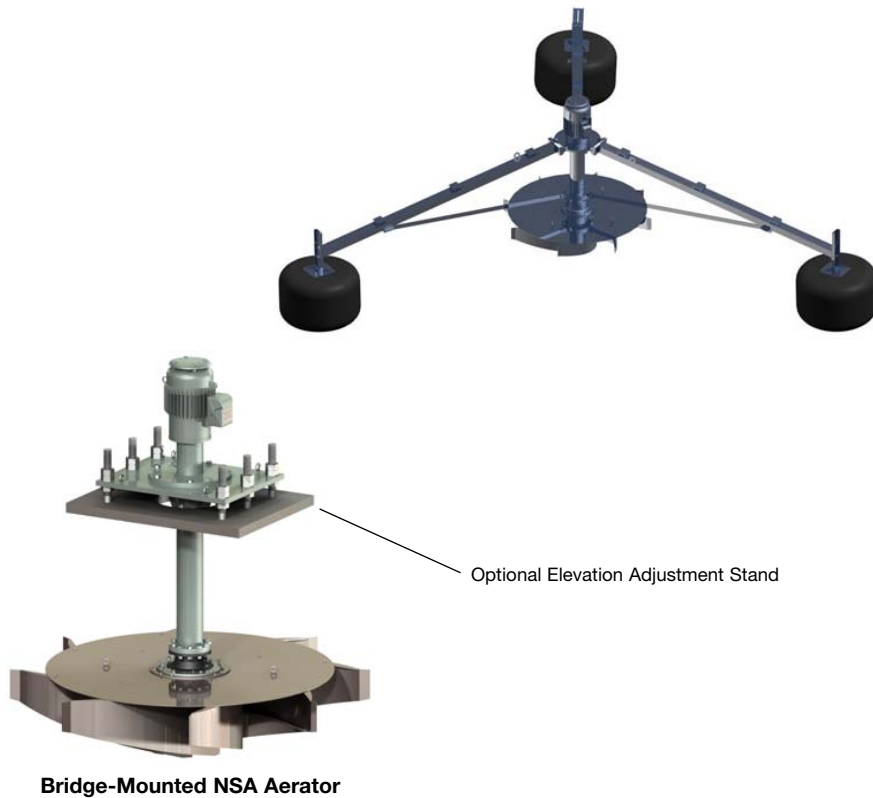

OIL CHANGE

With the oil change kit provided, oil change can be completed in about 15 minutes depending on the size of the aerator gearbox.

SUBMERGENCE ADJUSTMENT FOR FLOATING AERATOR

The exclusive “Rock and Adjust” joint (RA joint) permits easy submergence adjustment without using a crane.

OPTIONAL ELEVATION ADJUSTMENT STAND FOR BRIDGE-MOUNTED AERATOR

NSA bridge-mounted aerators are available with an optional elevation adjustment stand, which greatly simplifies installation.

Low Speed Aerators

Floating NSA Aerator

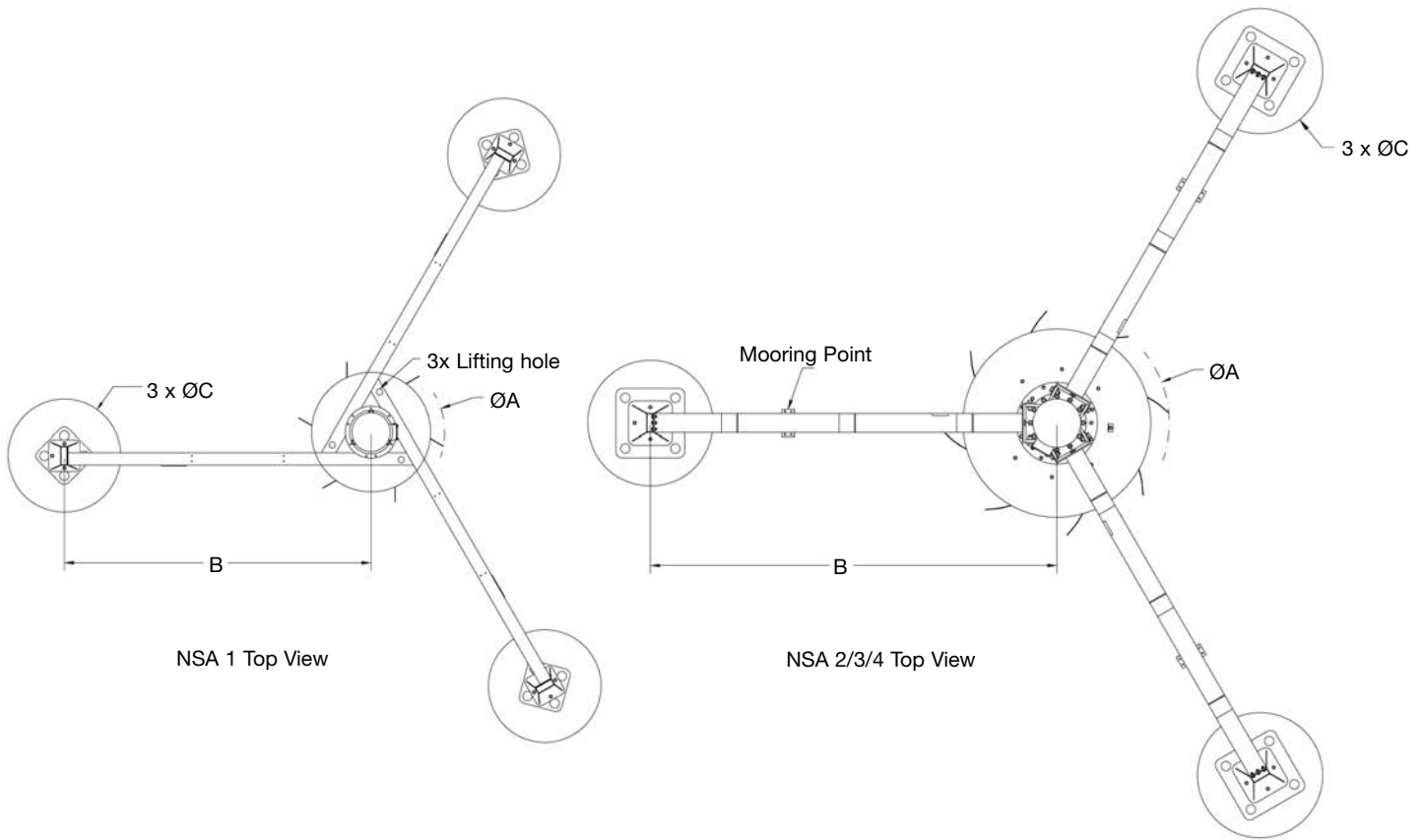

Model	Horse-power		Service Factor ¹		O ₂ /Hour ²		ØA 1800 rpm input		ØA 1500 rpm input		B		ØC		Weight	
	hp	kw	60hz	50hz	lb	kg	in	mm	in	mm	in	mm	in	mm	lb	kg
NSA1-08	7.5	5.6	6.50	5.40	26	12	42	1,067	46	1,168	98	2,489	38	965	1,047	475
NSA1-10	10	7.5	4.90	4.06	35	16	46	1,168	49	1,245	98	2,489	38	965	1,112	504
NSA1-15	15	11	3.25	2.70	53	24	49	1,245	52	1,321	98	2,489	38	965	1,203	546
NSA1-20	20	15	2.44	2.03	70	32	52	1,321	57	1,448	98	2,489	38	965	1,253	568
NSA2-25	25	19	3.84	3.20	88	40	68	1,727	74	1,880	130	3,302	40	1,016	1,960	889
NSA2-30	30	22	3.20	2.67	105	48	72	1,829	78	1,981	130	3,302	40	1,016	2,100	952
NSA2-40	40	30	2.40	2.00	140	63	76	1,930	83	2,108	169	4,280	46	1,168	2,558	1,160
NSA2-50	50	37	1.92	NR	175	79	80	2,032	NR	NR	169	4,280	46	1,168	2,682	1,216
NSA3-50	50	37	3.07	2.56	175	79	86	2,184	96	2,438	169	4,280	46	1,168	3,046	1,381
NSA3-60	60	45	2.56	2.13	210	95	88	2,235	99	2,515	169	4,280	46	1,168	3,264	1,480
NSA3-75	75	56	2.05	NR	263	119	91	2,311	102	2,591	169	4,280	46	1,168	3,500	1,587
NSA4-75	75	56	4.78	3.96	263	119	116	2,946	122	3,099	196	4,978	60	1,524	6,520	2,957
NSA4-100	100	75	3.59	2.97	350	159	122	3,099	130	3,302	196	4,978	60	1,524	6,847	3,105
NSA4-125	125	93	2.87	2.38	438	198	130	3,302	136	3,454	196	4,978	60	1,524	7,200	3,265
NSA4-150	150	112	2.39	1.98	525	238	136	3,454	144	3,658	196	4,978	60	1,524	7,700	3,492
NSA4-200	200	149	1.80	NR	700	317	144	3,658	NR	NR	196	4,978	60	1,524	8,400	3,810

¹Minimum recommended service factor is 1.8. At 1.0 service factor, gears have a theoretical infinite life.

²Under standard conditions. Performance under field conditions may vary.

NR: Not recommended.

Low Speed Aerators

Bridge-Mounted NSA Aerator

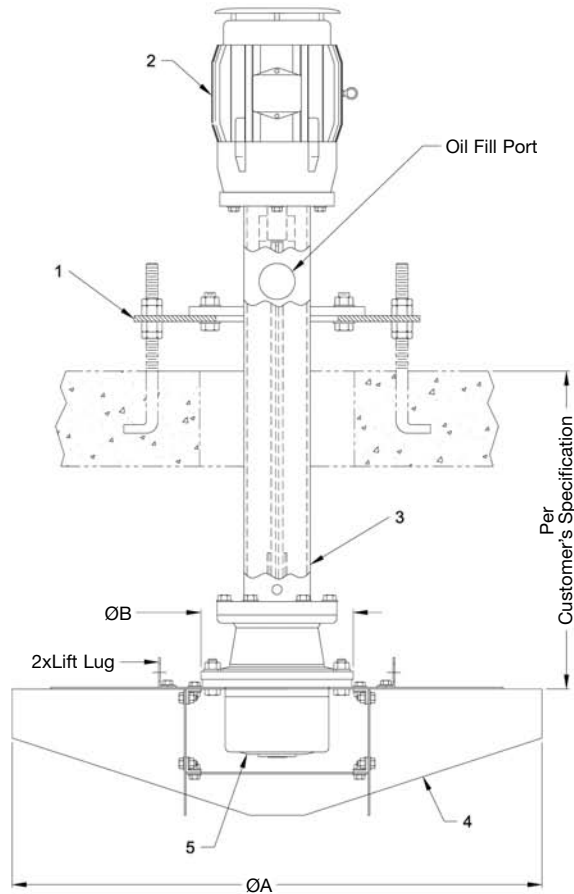

- | Item | Description |
|------|----------------|
| 1 | Mounting plate |
| 2 | Electric motor |
| 3 | Spool |
| 4 | Rotor |
| 5 | Gearbox |

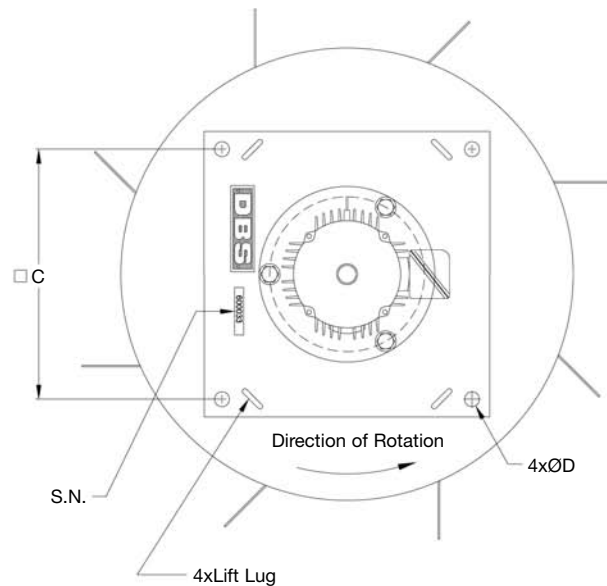

Model	Horse-power		Service Factor ¹		O2/Hour ²		ØA 1800 rpm input		ØA 1500 rpm input		B ³	C	D		Weight	
	hp	kw	60hz	50hz	lb	kg	in	mm	in	mm			in	mm	in	mm
NSA1-08B	7.5	5.6	6.50	5.40	26	12	42	1,067	46	1,168	13 330	20 508	1	25	659	299
NSA1-10B	10	7.5	4.90	4.06	35	16	46	1,168	49	1,245	13 330	20 508	1	25	724	328
NSA1-15B	15	11	3.25	2.70	53	24	49	1,245	52	1,321	13 330	20 508	1.25	30	815	370
NSA1-20B	20	15	2.44	2.03	70	32	52	1,321	57	1,448	13 330	20 508	1.25	30	865	392
NSA2-25B	25	19	3.84	3.20	88	40	68	1,727	74	1,880	19 483	30 762	1.5	40	1,515	687
NSA2-30B	30	22	3.20	2.67	105	48	72	1,829	78	1,981	19 483	30 762	1.5	40	1,655	751
NSA2-40B	40	30	2.40	2.00	140	63	76	1,930	83	2,108	19 483	30 762	2	50	2,113	958
NSA2-50B	50	37	1.92	NR	175	79	80	2,032	NR	NR	19 483	30 762	2	50	2,237	1,015
NSA3-50B	50	37	3.07	2.56	175	79	86	2,184	96	2,438	19 483	30 762	2	50	2,237	1,015
NSA3-60B	60	45	2.56	2.13	210	95	88	2,235	99	2,515	19 483	30 762	2.5	60	2,605	1,181
NSA3-75B	75	56	2.05	NR	263	119	91	2,311	102	2,591	19 483	30 762	2.5	60	2,742	1,244
NSA4-75B	75	56	4.78	3.96	263	119	116	2,946	122	3,099	28 711	40 1,016	3	80	4,804	2,179
NSA4-100B	100	75	3.59	2.97	350	159	122	3,099	130	3,302	28 711	40 1,016	3	80	5,131	2,327
NSA4-125B	125	93	2.87	2.38	438	198	130	3,302	136	3,454	28 711	40 1,016	3	80	5,484	2,487
NSA4-150B	150	112	2.39	1.98	525	238	136	3,454	144	3,658	28 711	40 1,016	4	100	6,148	2,788
NSA5-200B	200	149	2.70	2.25	700	317	144	3,658	165	4,191	28 711	40 1,016	4	100	6,988	3,169
NSA5-250B	250	186	2.16	1.80	875	397	156	3,962	177	4,496	28 711	40 1,016	4	100	7,683	3,484
NSA5-300B	300	224	1.80	NR	1,050	476	165	4,191	NR	NR	28 711	40 1,016	4	100	7,950	3,605

¹Minimum recommended service factor is 1.8. At 1.0 service factor, gears have a theoretical infinite life.

²Under standard conditions. Performance under field conditions may vary.

³Bridge platform must have a hole larger than B dimension for installation.

NR: Not recommended.

Low Speed Aerators

NSA Aerator Lubrication

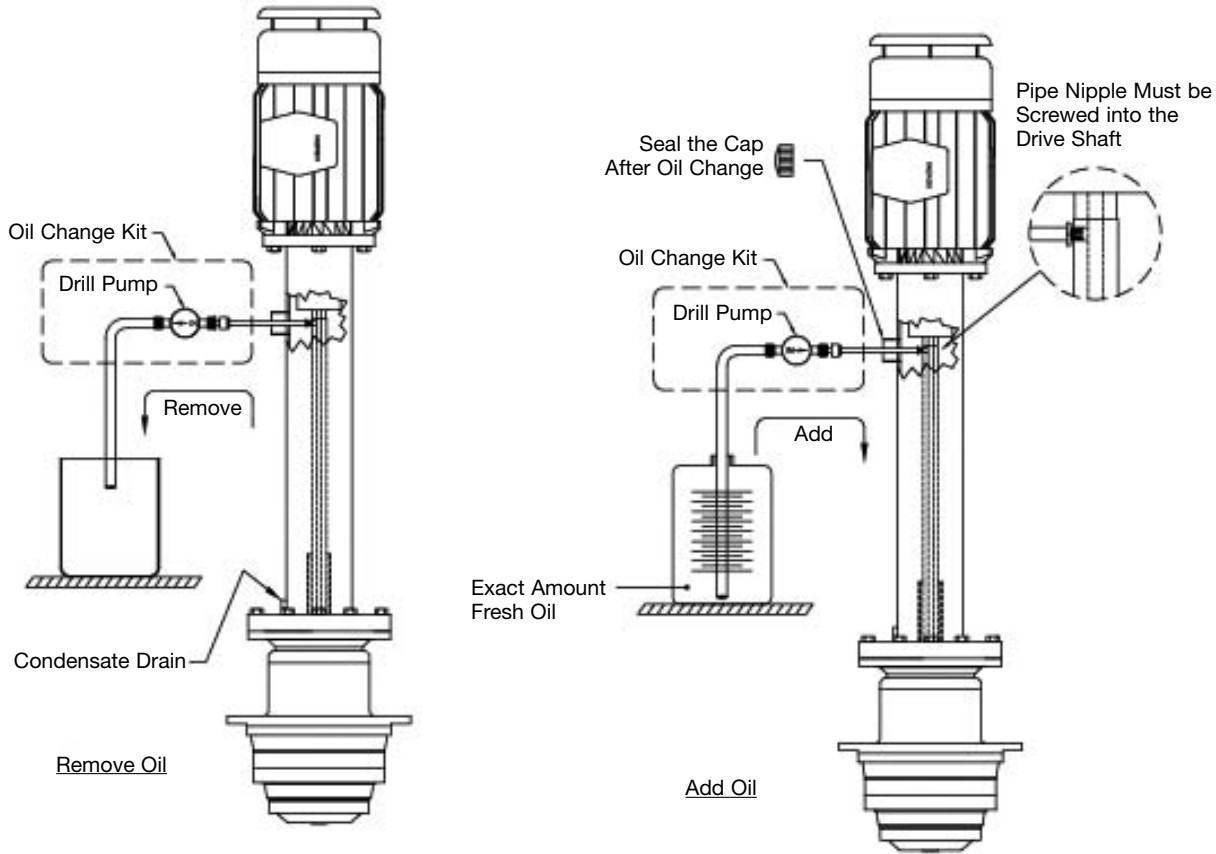

An oil change kit is provided with each NSA aerator. The kit includes oil pump, fittings, and the exact amount of synthetic oil for initial startup. Both removal and addition of oil is by pumping, similar to the oil change of a marine engine. The required oil volumes are as follows:

Model	Oil Capacity	
	gallon	liter
NSA1	0.75	2.8
NSA2	2.0	7.6
NSA3	3.25	12.3
NSA4	8	30.2
NSA5	10	37.8

Recommended oil change interval is every six months. Turn off the power before performing the oil change.

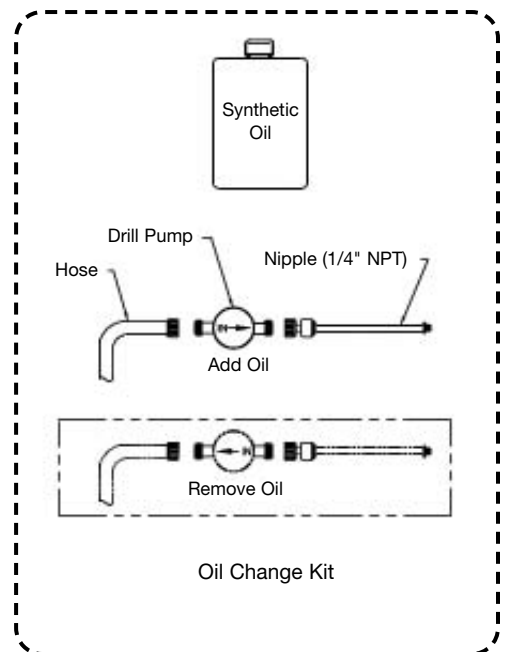

DBS High-Efficiency Aeration Rotors

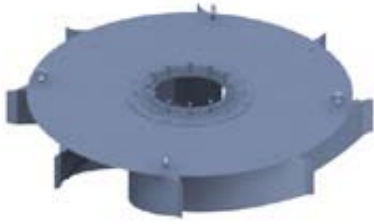

Standard backward curved blade rotor

DBS High-Efficiency Aeration Rotors

The aeration rotor is the device that does the work of pumping, mixing and aerating. Aeration rotors are commonly made of steel and have straight radial blades. “Top of the line” high efficiency rotors have backward curved blades that provide improved efficiency and a wider operating speed range. DBS offers two types of aeration rotors.

DBS Standard Aeration Rotor

The standard DBS aeration rotor uses fixed backward curved blades. These rotors are typically made from stainless steel and offer high pumping and aeration efficiency.

DBS Flexible Blade Rotor

This patented NSA aeration rotor uses cantilevered flexible radial blades. These blades are free to bend so when pumping loads are applied to the blades, they bend backward, assuming the desired curved profile at full speed and load. At less than full speed, the blades spring back and take on a more radial configuration. This change in profile is very important because the aeration rotor keeps the desired exit velocity of the water nearly constant over a wide speed range. This means that the aeration efficiency of the rotor is nearly constant over the operating speed range. The flexible blade aeration rotor is specifically beneficial in applications where a VFD controls the aerator to regulate oxygen levels in a lagoon or oxidation ditch.

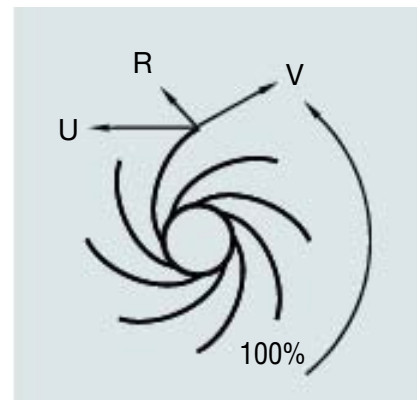
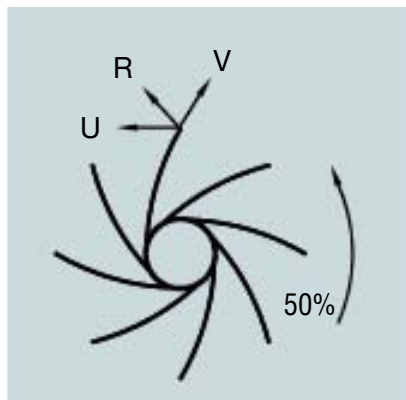
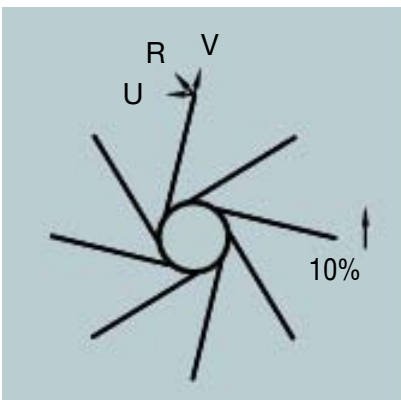

From a rotor speed of 50% to 100%, the exit velocity “R” is nearly constant. As rotor speed increases from 50% to 100% the additional energy is put into pumping greater volumes of water, not into higher water velocity.

Installation



Floating NSA1 as shipped

Basic Installation and Erection Procedures

The NSA is shipped in modules and is easy to assemble in the field. It typically requires a crane and crew of two to four people, depending on size of the machine.

1. Assemble the rotor.
2. Position the drive mechanism on the rotor. Bolt the rotor to the drive mechanism.
3. NSA1: bolt the arms to the center mechanism.
NSA 2, 3 and 4: bolt the arms to the top lugs of the center mechanism.
4. Install the lower link bars between the center mechanism and the arms.
5. Bolt the float assemblies to the arms.
6. Fill the gearbox with oil.
7. Use the crane to place the NSA in the water. Hook up mooring and electric cable to the machine.
8. Adjust floats for desired rotor immersion.

Floating NSA Aerator Mooring Options

GENERAL

Selection of a mooring arrangement is dependent on water level fluctuation, extreme weather, and the design of the aeration basin. Use the mooring accessories listed in the table below as minimum for normal applications. Applicable local, state and federal guidelines must be adhered to.

The key to mooring success is careful planning and engineering based on water level fluctuation, mooring distance, and weather conditions. Avoid any possibility of tangling the mooring cable in the rotor or rubbing and wearing damage to the cable.

Make sure the entire length of the mooring cable is visible. Use floats when the mooring cable is long. Three-cable mooring is preferred if the water level is stable. Two-cable mooring can better compensate for water level fluctuation, but the aerator tends to drift sideways when the mooring cables are long.

SHORE MOORING

A two-cable mooring system can be used when the aerator is close to shore. The minimum cable length is 10 feet (3 meters) plus the amount of water fluctuation squared.

POST MOORING





In large lagoons where distances prohibit mooring to shore, posts can be used for anchoring. The cable length can be calculated the same way as for shore moorings.

BOTTOM MOORING

If the mooring point is at the bottom of the basin, the mooring point and the trace of the mooring line must be flagged with floats. The minimum cable length is four times the basin depth plus the water fluctuation squared.

DIRECT POST MOORING

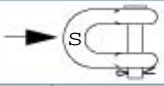
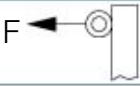
The arms of a floating aerator can be directly tied to the mooring posts. When this method is used, a sliding mechanism must be in place to compensate for water level changes.

Components		Mooring cable				Thimble/Cable clip		Shackle				Anchoring point	
Specification		High Flex 304 stainless steel, 7 x 19 cable				Stainless steel		Stainless steel					
Picture													
Key variables		D		Breaking strength				S		Work load limit		Test force	
		in	mm	lbs	N			in	mm	lbs	N	lbs	N
Minimum Recommendation	NSA1	0.19	5	3,700	16,444			0.38	10	2,000	8,889	1,300	5,778
	NSA2	0.25	7	6,400	28,444			0.38	10	2,000	8,889	4,000	17,778
	NSA3	0.25	7	6,400	28,444			0.50	13	4,000	17,778	4,500	20,000
	NSA4-75 to 125	0.31	8	9,000	40,000			0.63	16	6,000	26,667	10,000	44,444
	NSA4-150 and up	0.38	10	12,000	53,333	For proper cable size		0.75	20	8,500	37,778	14,000	62,222

Floating NSA Aerator Mooring Options

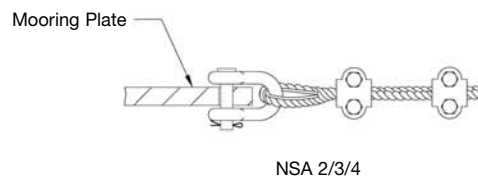
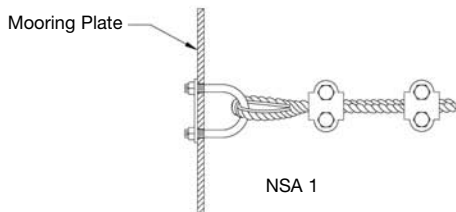
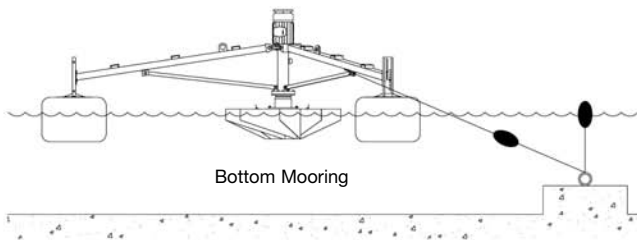
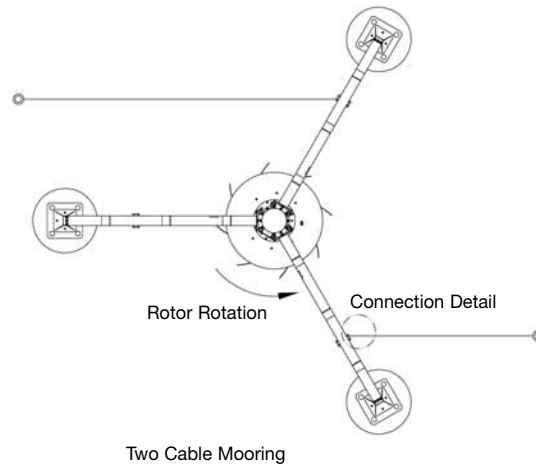
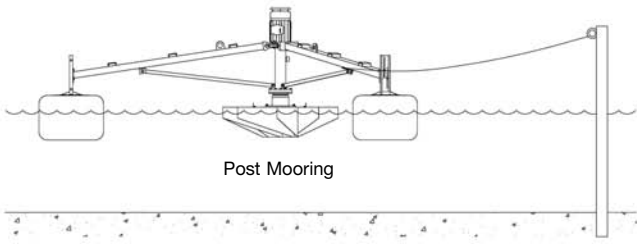
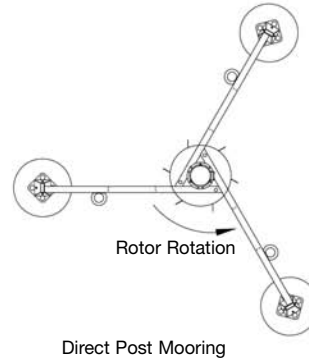
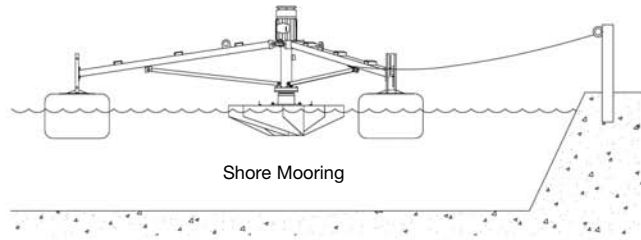

Connection Details

DBS “RaceTrack” Oxidation Ditch



Oxidation ditches are proven efficient and economical wastewater treatment systems that have been used for decades. DBS Manufacturing Inc., has taken this proven technology and improved upon it by incorporating the new DBS Aerator technology.

DBS Racetrack Oxidation Ditches are powered with the patented NSA low-speed aerator. These aerators provide high efficiency and long life at a substantially lower cost than competitive aerators. And, maintenance parts are available worldwide. DBS Racetrack Oxidation Ditch aerators are equipped with the DBS stainless steel high efficiency backward curved aeration rotor. This rotor maximizes pumping rate for superior mixing and aeration.

DBS Racetrack Oxidation Ditch offer guaranteed performance, not only for the mechanical equipment, but also for the biological process and ditch velocity.

Low Speed Aerators

Aerobic Digestors - Lagoon Aeration



DBS Floating Aerators are ideal for lagoon and aerobic digester applications. The compact design of the NSA floating aerator makes these units easy to assemble and install. All wetted parts such as the aeration rotor, float arm lower link, and float hardware are made from corrosion resistant stainless steel for long life and reliability.

Lagoon applications may benefit from the flexibility permitted by using the DBS stainless steel mooring winch. The use of two of these winches makes easy work of moving the DBS aerator across the lagoon to maximize mixing efficiency.





**Low Speed Aerators
NSA Series Aerators**

Clarifier & Thickener Drives

Retrofits

Low-Speed Surface Aerators

Rotary Distributor Center Mechanisms

DBS Manufacturing, Incorporated

45 SouthWoods Parkway, Atlanta, Georgia 30354 USA

404.768.2131 phone 404.761.6360 fax

www.dbsmfg.com email: engineering@dbsmfg.com