

Drive Units Technical Information



DBS MANUFACTURING®

Clarifier Drive Technical Features and Options

DBS specializes in the design and manufacture of clarifier and thickener drive units. Our engineering effort is to continually improve our products, to increase reliability and to reduce required maintenance. In addition, our drive products have always been engineered to integrate into modern process controls by providing accurate torque load sensing instrumentation.

DBS works closely with its customers to ensure that the drive unit provided meets the customers' requirements. DBS' flexible design and manufacturing processes allow DBS to easily modify standard design drives to reduce our customers' overall cost.

Torque Gauge



One of the most obvious design features of the DBS drive unit is its torque gauge. From the very first DBS drive unit, DBS has used a large diameter stainless steel gauge that accurately indicates torque in foot-pounds or Newton-meters. The DBS design is superior to a small dial or cast iron pointer that indicates 0-100%, or 1-10, or even "green-yellow-red." Other manufacturers' gauges give the operator very little useful data except a relative sense of how the loads on the clarifier change from time to time.

DBS torque gauges are all available with an optional 4-20 mA torque transducer for remote torque monitoring and process control. Accurate torque information from the 4-20 mA transducer allows industrial users to increase the throughput and efficiency of their process.

The advantages of the DBS torque gauge are:

1. DBS torque gauge is calibrated in units of torque such as: ft-lbf or N-m.
2. DBS torque gauge alarm and cutoff switches are easily adjustable in the field with common hand tools.
3. DBS offers an optional 4-20 mA torque transducer on all drives for remote torque indication or process control.
4. The torque gauge and switches on drives equipped with the F-type or H-type primary reducer will also operate when the drive is reversed.

E-Type Primary Reducer

The E-type primary speed reducer uses helical gears for speed reduction. Many reduction ratios are available to precisely match the desired drive output speed. The E-type design provides alarm and cutoff switches, and a shear pin for triple overload protection. Reaction force from the gearbox pushes on a hydraulic cylinder, generating hydraulic oil pressure which is directly proportional to the torque load on the drive unit. The alarm and cutoff pressure switches, located inside the torque gauge box, are adjustable to any torque value. They can be wired to sound an audible or visual alarm and to cut electrical power to the driving motor. The gearbox also has an easily replaceable shear pin as a third means of overload protection. Variable speed, if desired, can be achieved through either a mechanical disc or cone type mechanism or a VFD (Variable Frequency Drive).



F-Type Primary Reducer

F-type primary speed reducers are truly the “State of the art.” These primary speed reducers incorporate a hydraulic pump and motor fully enclosed in a reservoir for clean operation. F-type primary speed reducers perform several important functions:



- **Speed reduction:** Many reduction ratios are available.
- **Torque-limiting:** Maximum torque cannot be exceeded. Once maximum torque is reached, the drive will slow down but still maintain torque. This is analogous to a truck shifting into lower gears when pulling a load up a hill.
- **Low maintenance:** Change oil filters every three months.
- **Long life:** Hydraulic components have been proven to last for years in continuous duty industrial clarifier and thickener applications.
- **Easy repair:** All components can be removed with common hand tools. No special skills or training is required to maintain unit. Most items can be replaced with alternate brands.
- **Reversibility:** An optional directional control valve can provide easy reversing to allow clarifier or thickener rakes to be backed out of an overload condition.
Torque overload protection is maintained when operating in reverse.

F-Type Primary Reducer

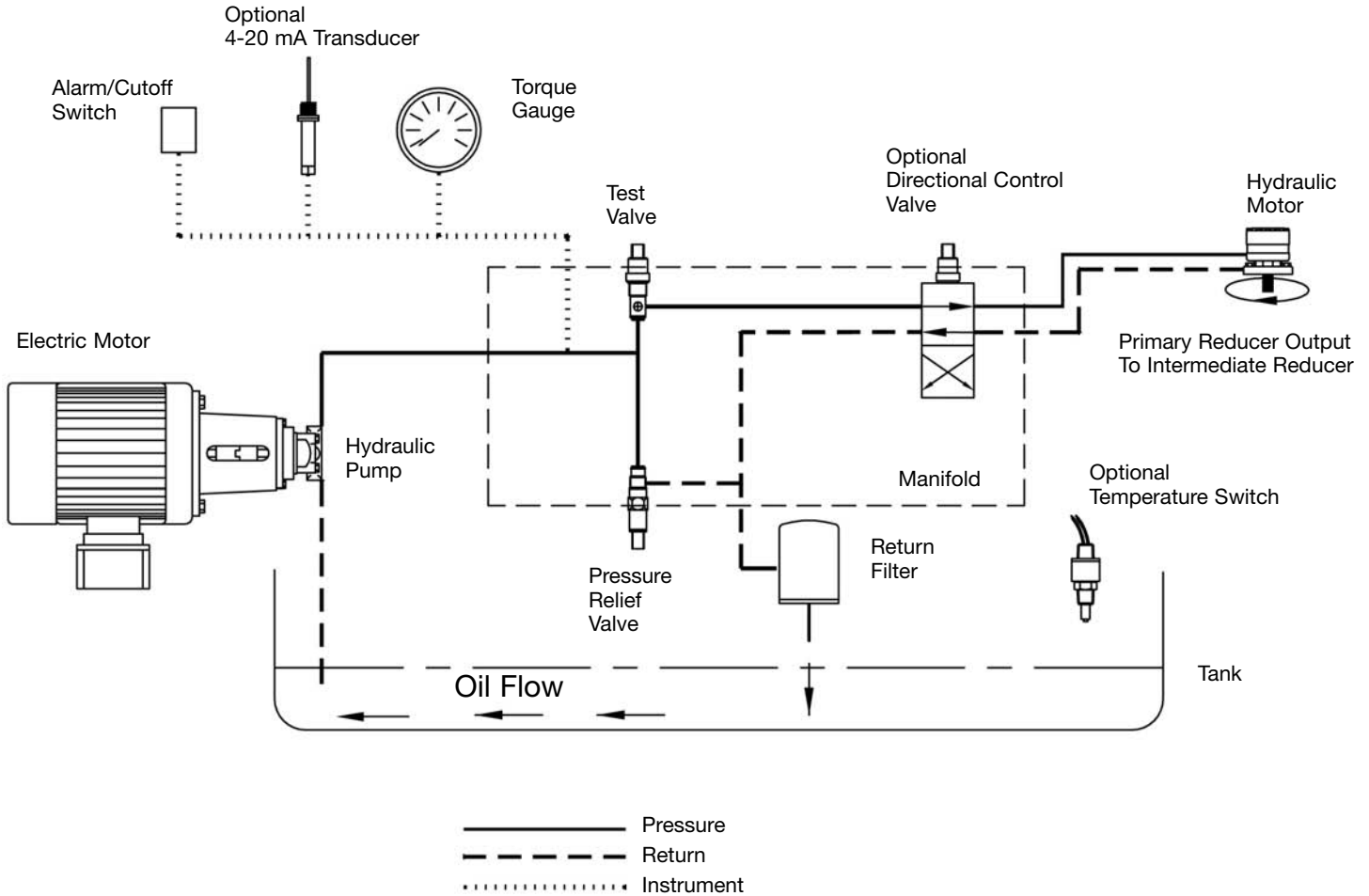

The main features of the F-type primary speed reducer are its reliability and its ability to operate at high torque in or near a stall mode. In a high load, overtorque situation, the F-type primary speed reducer will keep the clarifier or thickener operating if at all possible. If the rakes are truly stuck, the F-type primary speed reducer will simply stall at a high, but safe, torque.

The operation of the F-type primary speed reducer is simple. The electric motor drives a hydraulic pump that delivers oil to a hydraulic motor. The hydraulic motor drives the output drive shaft of the F-type primary speed reducer. The displacement of the pump is much smaller than the displacement of the motor. This difference in displacement between hydraulic pump and motor results in speed reduction. A pressure relief valve provides torque-limiting protection.

Since the system pressure is directly proportional to the torque load, the torque gauge and switches operate by monitoring the system pressure. This provides an accurate torque reading and a pressure signal that can be used to drive a 4-20 mA torque transducer.

H-Type Primary Reducer

The H-Type primary speed reducer is much like the F-type except it has a stand alone industrial hydraulic power unit. This design is typically used on higher horsepower applications and multiple pinion drives. Variable speed is achieved by a variable displacement hydraulic pump. A screw on the pump is used to control pump displacement, changing the oil flow rate, which is directly proportional to hydraulic motor speed.

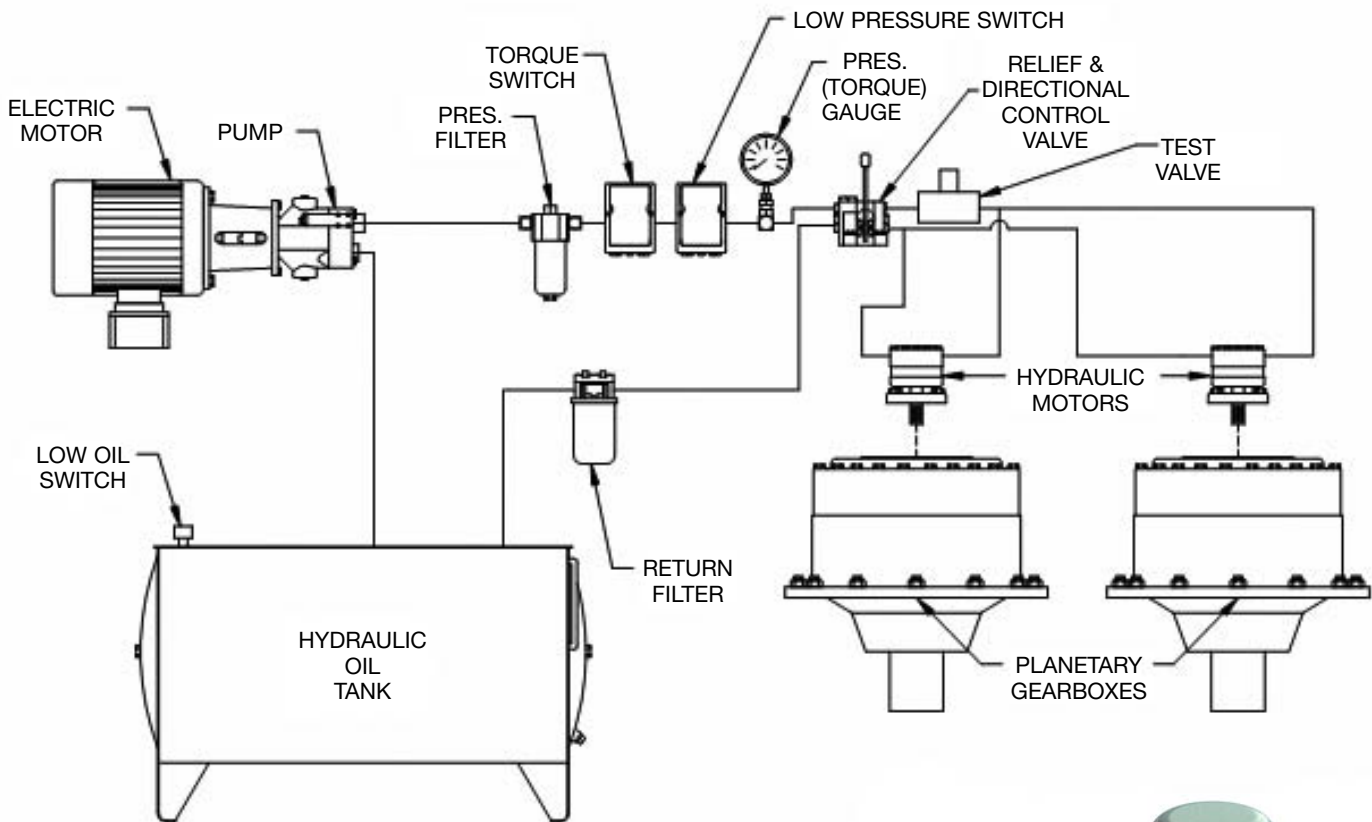

W-Type Primary Reducer

The W-type design uses helical gears for speed reduction. It has shear pin to protect the drive unit against torque overloads. This is simplified E-type design used where a torque gauge and adjustable alarm switch are not required.



Secondary Speed Reducer Features

DBS drive units use high capacity planetary gearboxes as secondary speed reducers to drive the main pinion gear on large drives and act as the main drive on smaller DBS drives. These planetary gearboxes are efficient and have bearing lives in excess of 100,000 hours. Planetary gearboxes are more efficient and have a longer life than typical worm-type pinion drive gearboxes, and have higher bearing capacity than cycloidal-type reducers.

DBS pinion drive gearboxes have very heavy-duty bearings that support the drive shaft. These bearings can fully support a drive pinion without the need of a bearing below the pinion, thus eliminating one common source of drive failure inherent with other brands. These bearings can also fully support a small clarifier rake mechanism.

DBS pinion drive gearboxes are permanently lubricated and require no maintenance for 10 years.

The advantages of the DBS secondary speed reducer are:

1. Spur gear planetary gearbox with a much higher efficiency and longer life than worm-type gearboxes.
2. High capacity bearings have L10 life in excess of 100,000 hours at full torque load.
3. The gearbox does not require a bearing under the drive pinion, resulting in superior reliability. Many competitors' drive units fail due to the failure of the lower pinion support bearing. Lower bearings are subject to contamination by debris and condensate (water) that sink to the lowest parts of the drive where the lower support bearing is located.

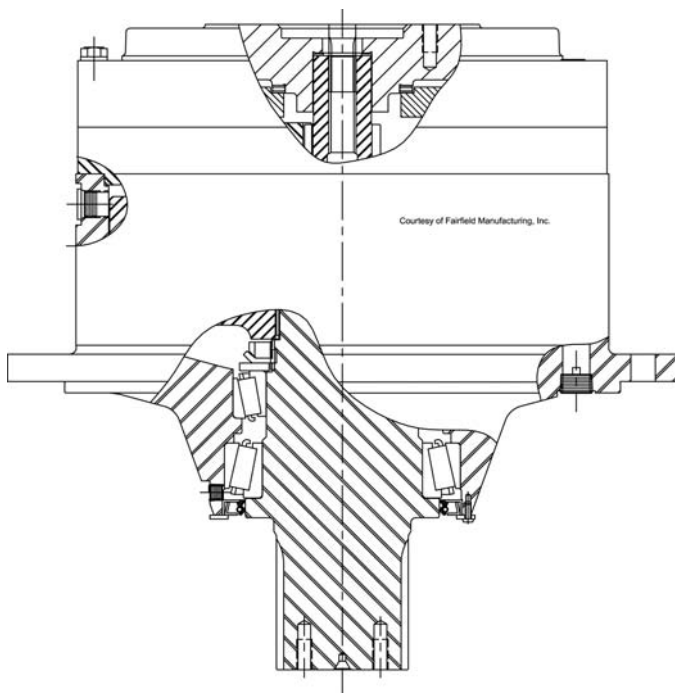

Main Gear & Bearing

The heart of any clarifier or thickener drive unit is the main gear and bearing. DBS has set a high standard for these components using forged alloy steel for the main gear, and a high capacity precision ball bearing to support the gear and the rotating clarifier mechanism. All DBS gears are rated per AGMA or ISO standards for 20 years at full torque load. DBS main bearings are rated per AFBMA or ISO standards to provide in excess of 100 years life. The conservative DBS approach pays off in high reliability and the ability of the drive to withstand lapses in specified drive maintenance.

	DBS	Competition
Main Gear	Forged alloy steel	Cast iron or cast steel
Main Bearing	4 point contact precision bearing with L10 life in excess of 100 years	L10 life 10 years
	10-year warranty	1-year warranty

AGMA GEAR STANDARDS

AGMA is the American Gear Manufacturers Association. This association publishes standards to be used by gear designers to design and size gear systems, or to provide torque and power ratings for a known gear system. The AGMA Standards are comparable to the ISO standards.

DBS Manufacturing was the first U.S. manufacturer of clarifier drive units to rate its drives per the AGMA Standards and to publish those ratings.

AGMA 2001-C95 & ISO 6336

AGMA 2001-C95 and ISO 6336 are the current standards for rating spur and helical gears.

These rating systems provide two ratings for an analyzed gear set:

1. Surface Durability, or the resistance to gear tooth surface spalling and pitting.
2. Strength, or the resistance to fatigue or tooth cracking failure.

The rating of any gear system is the LOWER torque value of the two.

AGMA 6034-B92 & ISO 14521

AGMA 6034-B92 and ISO 14521 are the current standards for rating worm gears. DBS does not use worm gears for the final drive gears; however, other manufacturers do use worm gears on their small to mid-range bridge-mounted (shaft output) type drive units.

IMPORTANT: Torque ratings for worm gears and for spur gears are not directly comparable. Worm gears operate by the worm shaft sliding (or threading itself) across the face of the worm gear. This sliding means wear. Torque ratings for worm gears are normally for only 25,000 hours or about three years. DBS spur gears are rated for 20 years or more.

OTHER TORQUE RATINGS

Some of the “torque ratings” used by various manufacturers are:

- Duty Rated Torque
- Peak Torque
- Operating Torque
- Design Torque

None of these ratings are determined by AGMA or other published standards. These torque ratings cannot be used to make a fair comparison between different manufacturers’ drive units.

Drive Units Technical Information

Lift Mechanism

Nearly all DBS drive units are available with an optional lifting mechanism. Lifts can be manually operated or power driven. DBS uses heavy-duty acme thread screw jacks to raise and lower the thickener rake mechanism.

The S-series drive unit provides rake lift by using a telescoping drive shaft, which lifts into the drive housing. The drive shaft is driven through two brass or bronze keys that offer low sliding friction and long life. Competitors' products use steel keys, which have higher friction and will corrode and lock up if not properly lubricated.

The DBS S-series drive unit lifting mechanism transfers all the lifting loads, the weight of lifted rakes and drive shaft plus the lifting forces, directly into the steel frame of the drive unit. In contrast, competitors' products feed all the loads through the main drive bearing, compromising bearing life.

The D-series drive unit raises the rake mechanism by lifting the entire drive unit. The lift is completely enclosed in the drive unit, eliminating the need to modify the center column or provide external structure. The torque reaction is transferred to the center column through low friction keys or torque reaction pads.

Other advantages of the DBS lifting mechanism are:

1. The DBS lifting mechanism does not require any external part of the drive unit to rotate to accommodate the lifting action.
2. The DBS lift screw jack is stationary for easy inspection and service.
3. The DBS lift does not use a "slip ring" electric connection.
4. The powered lift mechanism provides positive lift force control to prevent damage to the rakes or screw jack.
5. In most cases, the installation of a DBS lift-equipped drive unit is no more complicated than a non-lifting clarifier drive.
6. DBS offers an optional 4-20 mA lift position transducer for remote indication of lift position.

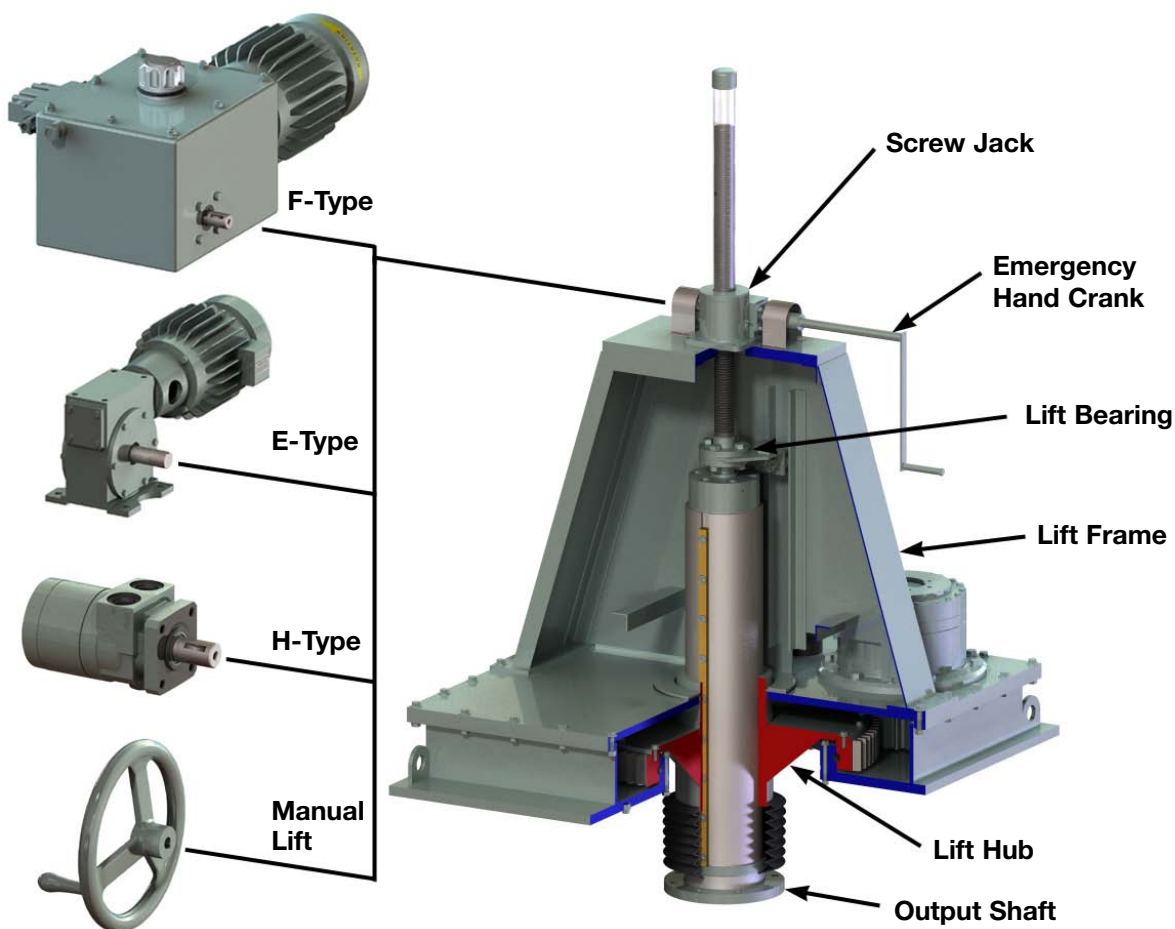

Condensate Control Unit

The DBS Condensate Control Unit – CCU – effectively keeps condensate out of the main gear housing. Moisture condensation inside a drive unit can contaminate the lubricating oil, leading to corrosion of the drive gears and bearings. If condensate is left to accumulate in a drive unit, it can displace the lubricant, leading to drive failure.

The DBS CCU takes air from the surroundings, heats it up to reduce its relative humidity, and blows it into the main gear housing. The constant flow of non-saturated dry air keeps the moisture level inside the bearing housing below saturation level to eliminate condensation problems. The CCU also keeps a slight positive pressure inside the main gearbox housing that prevents moisture from coming through the seals.

The DBS CCU significantly cuts down on the machine maintenance demand and increases oil life.

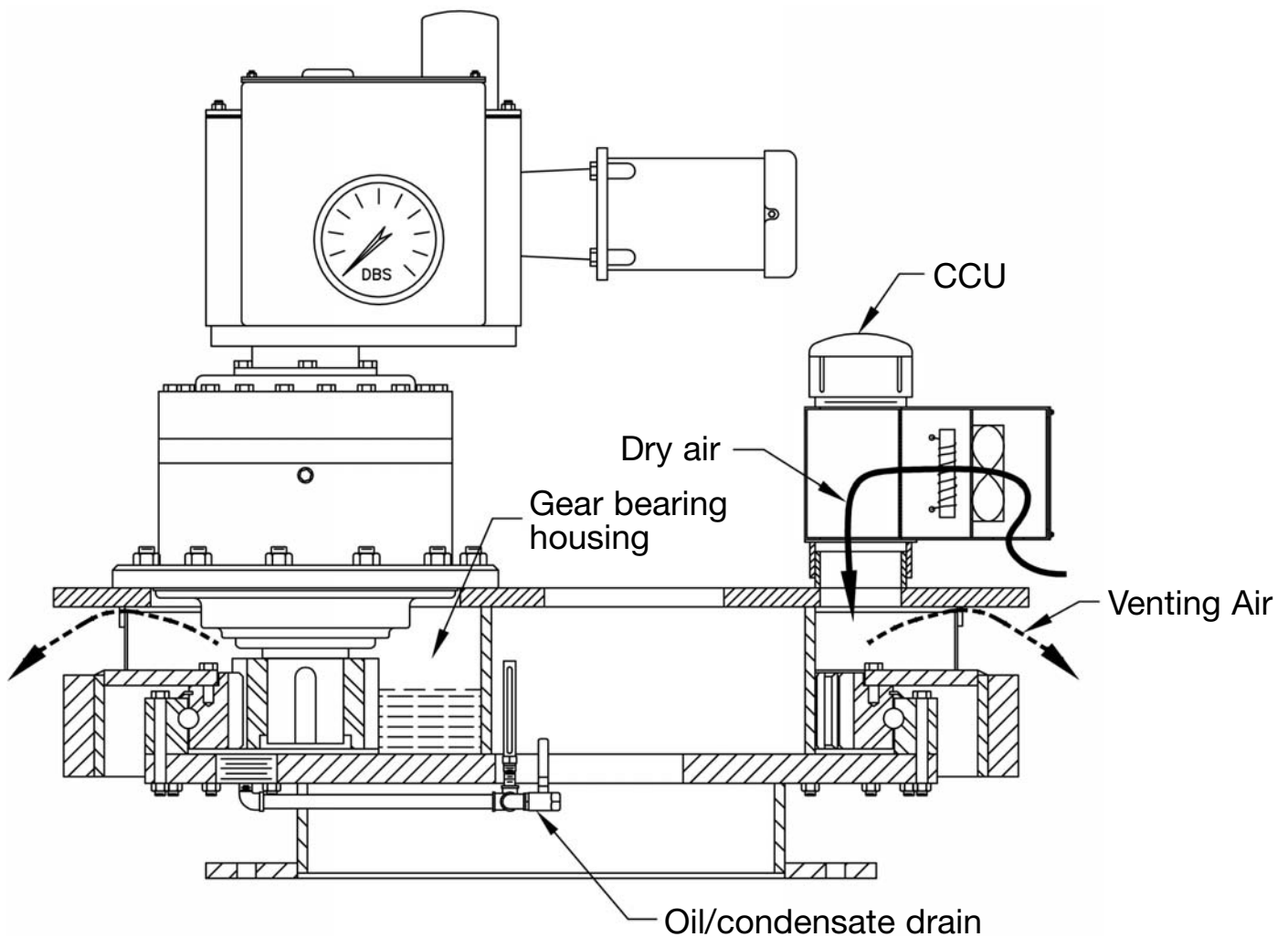

Output Flange Specifications¹

Flanges used with bridge-mounted drive units (SX-Series)											
Nominal Size	OD of Flange (A)		ID of Flange (B)		Thickness of Flange (T)		Number of Bolt Holes	Dia. of Bolt Holes		Dia. of Bolt Hole Circle (C)	
in	in	mm	in	mm	in	mm		in	mm	in	mm
4	9.00	228.6	4.57	116.1	0.625	15.9	8	0.750	19.1	7.50	190.5
5	10.00	254.0	5.66	143.8	0.625	15.9	8	0.875	22.2	8.50	215.9
6	11.00	279.4	6.72	170.7	0.688	17.5	8	0.875	22.2	9.50	241.3
8	13.50	342.9	8.72	221.5	0.688	17.5	8	0.875	22.2	11.75	298.5
Flanges used with bridge-mounted drive units (S-Series)											
Nominal Size	OD of Flange (A)		ID of Flange (B)		Thickness of Flange (T)		Number of Bolt Holes	Dia. of Bolt Holes		Dia. of Bolt Hole Circle (C)	
in	in	mm	in	mm	in	mm		in	mm	in	mm
4	9.00	228.6	4.57	116.1	0.938	23.8	8	0.750	19.1	7.50	190.5
5	10.00	254.0	5.66	143.8	0.938	23.8	8	0.875	22.2	8.50	215.9
6	11.00	279.4	6.72	170.7	1.000	25.4	8	0.875	22.2	9.50	241.3
8	13.50	342.9	8.72	221.5	1.125	28.6	8	0.875	22.2	11.75	298.5
10	16.00	406.4	10.88	276.4	1.188	30.2	12	1.000	25.4	14.25	362.0
12	19.00	482.6	12.88	327.2	1.250	31.8	12	1.000	25.4	17.00	431.8
14	21.00	533.4	14.19	360.4	1.375	34.9	12	1.125	28.6	18.75	476.3
16	23.50	596.9	16.19	411.2	1.438	36.5	16	1.125	28.6	21.25	539.8
18	25.00	635.0	18.19	462.0	1.563	39.7	16	1.250	31.8	22.75	577.9
20	27.50	698.5	20.19	512.8	1.688	42.9	20	1.250	31.8	25.00	635.0
22	29.50	749.3	22.19	563.6	1.813	46.0	20	1.375	34.9	27.25	692.2
24	32.00	812.8	24.19	614.4	1.875	47.6	20	1.375	34.9	29.50	749.3
26	34.25	870.0	26.19	665.2	2.000	50.8	24	1.375	34.9	31.75	806.5
28	36.50	927.1	28.19	716.0	2.000	50.8	28	1.375	34.9	34.00	863.6
30	38.75	984.3	30.19	766.8	2.000	50.8	28	1.375	34.9	36.00	914.4

¹Metric flanges and special flanges are available.

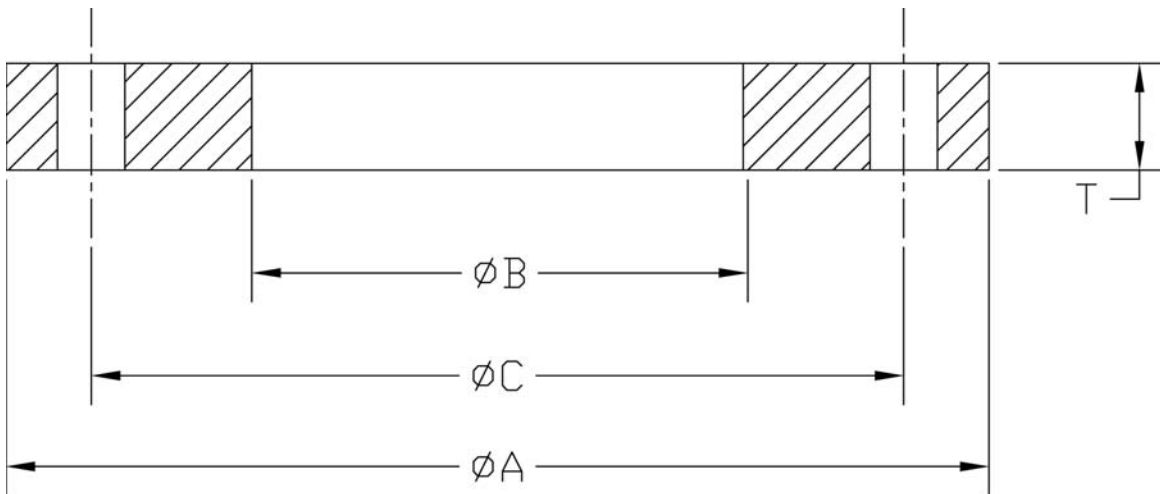

Options Available for Drive Units

- **Special electric motors** – Modifications available are space heaters, thermistors, oversized conduit boxes, explosion proof protection, terminal blocks, special nameplates, tropicalization, ground screws and weatherproofing.
- **Metric components** – Electric motors available with IEC metric frame sizes and IP55 protection. International industry standard couplings, fittings, and piping are available for all primary speed reducers. Speed reducers available from well established gearbox manufacturers in Europe or Japan.
- **Variable speed** – Variable speed is available with all primary reducers.
 - The H-Type uses a variable volume piston pump providing a 3:1 speed variation.
 - The F-Type utilizes a Variable Frequency Drive (VFD) to provide a 3:1 speed variation.
 - The speed of the E-type reducer can be mechanically or electrically controlled using a disc type or ring cone type mechanical reducer or a VFD for electrical control. The mechanical variable speed reducers have a 5:1 variation and the VFD's have a 10:1 variation.
 - The VFD's are available with Nema 1 or Nema 4X enclosure.
- **Reversing** – The reverse capability will allow the operator to back the rakes off the sludge. The reverse feature is available with all primary reducers.
- **Special coatings** – These include, but are not limited to, urethane coatings, epoxy coatings, zinc rich coatings and any other modern coatings.
- **Non-skid surface** – Placed on the top platform of the drive unit.
- **4-20 mA torque transmitter** – For remote indication of torque or process control.
- **Loss motion switch** – The sensor is placed in the final gearbox and detects number of pulses per minute. The device is used to indicate that the rakes are turning.
- **Oil heaters** – Oil heaters are available for F-type and H-type primary speed reducers and final main gear housings.
- **Space heaters** – Space heaters are available for the torque gauge box.
- **Temperature switches** – Generally used to protect the oil against overheating when oil heaters are used.
- **Oil level switches** – Are available for the F-type and H-type primary speed reducers and final main gear housings.
- **Explosion proof switches** – Used for hazardous and explosive environments.
- **Stainless steel housings** – The torque gauge box, F-type and H-type reservoirs are available in stainless steel type 304 material.
- **Lift mechanism** – This feature is used for lifting the rakes when operating under higher load conditions.
- **4-20 mA lift position transmitter** – For remote indication of the position of the rakes.
- **Condensate control unit (CCU)** – This option greatly reduces condensation in the final gear-bearing housing by flowing low relative humidity air into the gear-bearing housing.



**Drive Units Technical Information
Torque Gauge**

Clarifier & Thickener Drives

Retrofits

Low-Speed Surface Aerators

Rotary Distributor Center Mechanisms

DBS Manufacturing, Incorporated

45 SouthWoods Parkway, Atlanta, Georgia 30354 USA

404.768.2131 phone 404.761.6360 fax

www.dbsmfg.com email: engineering@dbsmfg.com